

Customer: _____

PO #: _____

Job Name: _____

Quote#: _____

Date: _____

Quantity: _____

Ship To: _____

Notes: _____

Standard Features

- One-piece unit
- AcrylX™ applied acrylic
- Slip-resistant floor

Interior Dimensions: 56" W x 31" D x 79" H
 Exterior Dimensions: 59 ¾" W x 32" D x 80 ½" H
 Skirt Height: 14 ½"
 Weight: 175 lbs
 Wall Finish: Smooth
 Drain Location: End (Left or Right)
 Material: AcrylX™

CONFIGURATION (handed by seat)

Fully Configured Drain Location: Left-Handed Drain Right-Handed Drain

Includes: Symmons® pressure balance mixing valve with concealed check stops; Moen® hand held shower head with hose and stainless steel slide bar/grab bar; tension rod; two 18" stainless steel grab bars; one 22" stainless steel grab bar; two 36" stainless steel grab bars; molded-in corner soap dish

CUSTOM OPTIONS (Not Available if Fully Configured Option is selected)

Seat: Left-Handed Phenolic Seat Right-Handed Phenolic Seat

Straight Grab Bars (All Grab Bars are Stainless Steel unless otherwise noted):

12"(left side wall) – QTY: _____ 12"(right side wall) – QTY: _____ 16" – QTY: _____ 18" – QTY: _____

Location: _____ Location: _____ Location: _____

22" – QTY: _____ 24" – QTY: _____ 26" – QTY: _____

Location: _____ Location: _____ Location: _____

Fixture Wall: Left Right Back

Hand-held shower assembly with 30" slide bar and 60" hose

Pressure balancing mixing valve

OPTIONAL ACCESSORIES

Shower Curtain Curtain Rod 2" Drain Collapsible Water Dam

ANY ALTERATIONS TO ACCESSORIES SHOWN BELOW, PLEASE NOTE ON THESE DRAWINGS.

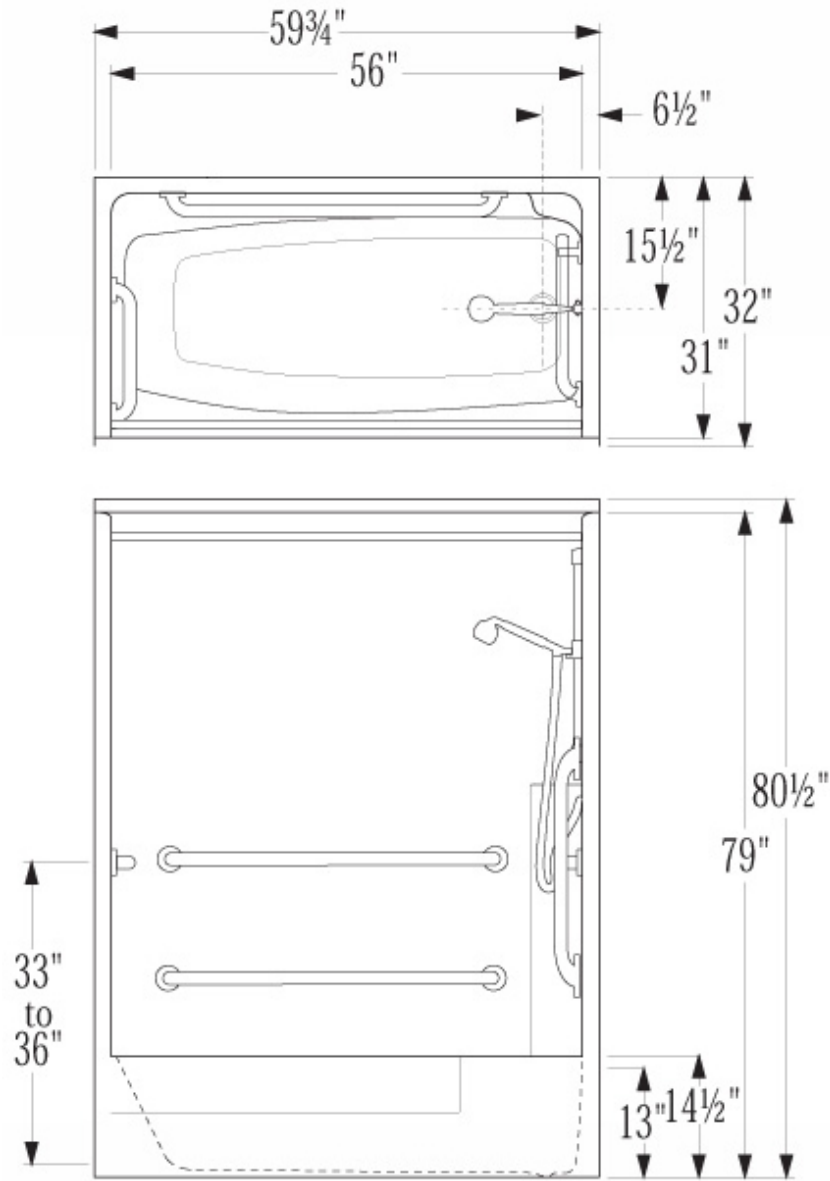

Plumbing Contractor Approval: _____ Date: _____

General Contractor Approval: _____ Date: _____

Engineer Approval: _____ Date: _____

Architect Approval: _____ Date: _____