

FLORESTONE
MODEL 20WM
UTILITY SINK

20" x 24" x 13½"

Weight:

20WM-1 (1/Box): 30 lbs.

20WM-3 (3/Box): 85 lbs.

Capacity: 19 gallons



Architect's Specifications

Furnish and install Utility Sink Model 20WM as manufactured by Florestone Products Co. Wall mounted sink to include wall mounting bracket and hardware to attach unit to wall. Color will be white and will be resistant to fading and abrasion. Unit to have 1½" drain opening.

Options and Accessories

20WM Accessory Kit

Drain Plugs with Hardware

Standards



I.A.P.M.O. File No. 2647

ANSI-Z 124.6 -97



CSA Test • Warnock Hersey Listed:

CAN/CSA-B45.0 — CAN/CSA-B45.5



FLORESTONE
Quality Shower and Bath Products Since 1947.

FLORESTONE PRODUCTS CO., INC.

2851 Falcon Dr. • Madera, CA 93637-9287

Tel: 559-661-4171 • Fax: 559-661-2070

www.florestone.com

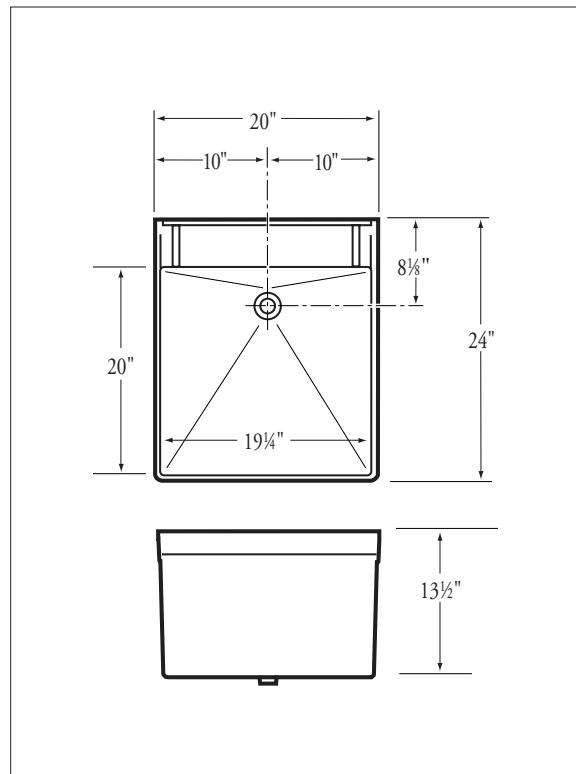

Inside Tray Dimensions: 20" x 19¼"