



**Florestone
Model FM
Utility Sink**

23¹/₈" x 22³/₈" x 35¹/₂"

	Weight:
FM-1 (1/Box):	30 lbs.
FM-3 (3/Box):	85 lbs.
Capacity	20 gallons

**Architect's
Specifications**

Furnish and install Utility Sink Model FM as manufactured by Florestone Products Co. Floor mounted sink to come with four (4) heavy duty molded legs and the hardware to attach legs to the sink, and drain plugs with hardware.

Color will be white and will be resistant to fading and abrasion.

Unit to have 1¹/₂" drain opening.

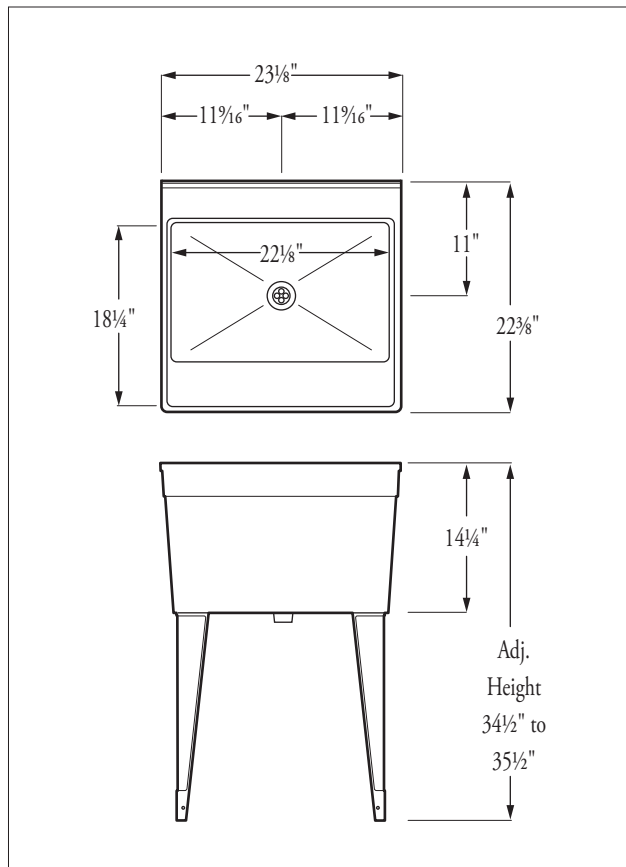

Inside Tray Dimensions: 18¹/₄" x 22¹/₈"

Optional and Accessories

- FM Accessory Kit
- Set of Legs (4) – Heavy duty molded legs

Standards

I.A.P.M.O. Listed File 2647
ANSI-Z-124.6-97

CSA Test • Warnock Hersey Listed:
CAN/CSA-B45.0 – CAN/CSA-B45.5



FLORESTONE PRODUCTS CO., INC.

2851 Falcon Drive • Madera, CA 93637

T. 559.661.4171 • T. 800.446.8827

F. 559.661.2070 • florestone.com

**Florestone
Model FMD
Utility Sink**

45⁵/₈" x 21⁵/₈" x 35¹/₂"

FMD (1/Box):
Capacity

Weight:
62 lbs.
38 gallons

**Architect's
Specifications**

Furnish and install Utility Sink Model FMD as manufactured by Florestone Products Co. Unit to have two sinks, four (4) heavy duty molded legs and the hardware to attach legs to the sinks, and drain plugs with hardware.

Color will be white and will be resistant to fading and abrasion.

Unit to have 1¹/₂" drain opening.

Optional and Accessories

FM Accessory Kit

Set of Legs (4) – Heavy duty molded legs

Standards

I.A.P.M.O. Listed File 2647
ANSI-Z-124.6-97



CSA Test • Warnock Hersey Listed:
CAN/CSA-B45.0 - CAN/CSA-B45.5

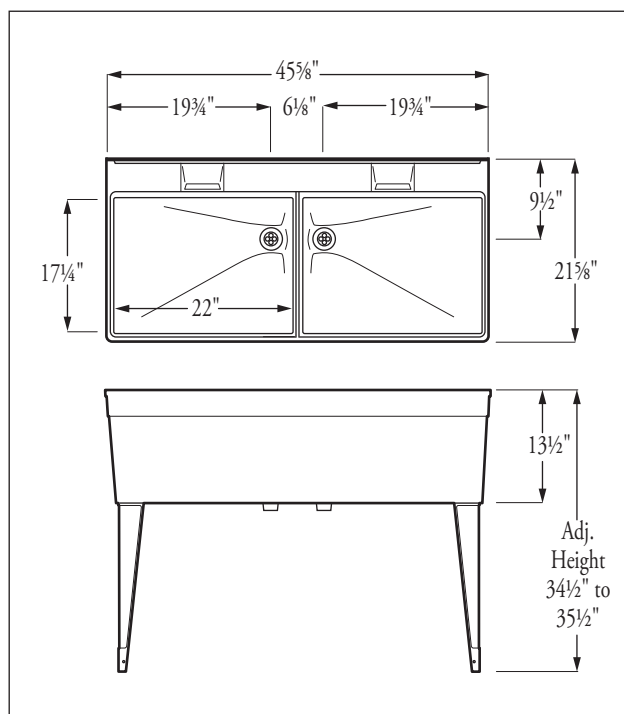

Inside Tray Dimensions: 17¹/₄" x 22"



FLORESTONE PRODUCTS CO., INC.

2851 Falcon Drive • Madera, CA 93637

T. 559.661.4171 • T. 800.446.8827

F. 559.661.2070 • florestone.com



**Florestone
Model WM
Utility Sink**

22 $\frac{3}{8}$ " x 22 $\frac{3}{8}$ " x 14 $\frac{1}{4}$ "

WM-1 (1/Box):
WM-3 (3/Box):
Capacity

Weight:
30 lbs.
85 lbs.
20 gallons

**Architect's
Specifications**

Furnish and install Utility Sink Model WM as manufactured by Florestone Products Co. Wall mounted unit to include wall mounting bracket and hardware, and drain plugs with hardware.

Color will be white and will be resistant to fading and abrasion.

Unit to have 1 $\frac{1}{2}$ " drain opening.

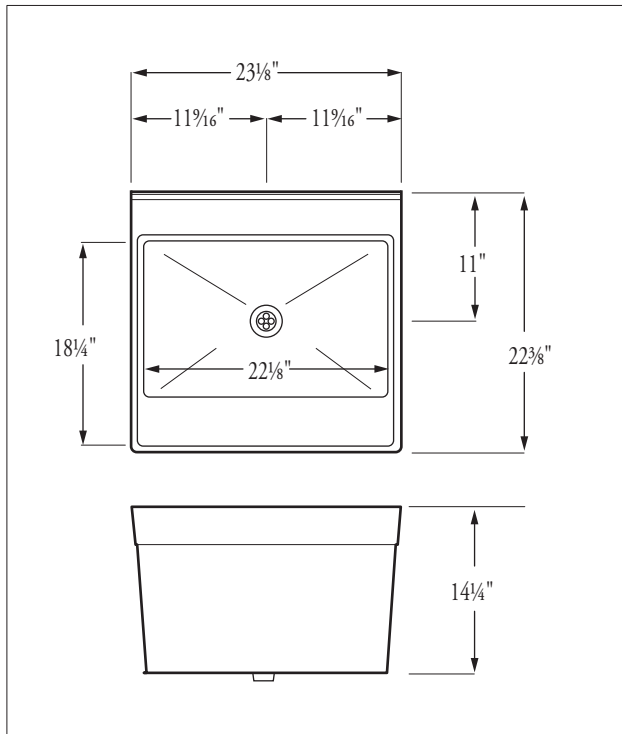

Inside Tray Dimensions: 17 $\frac{1}{4}$ " x 22 $\frac{3}{8}$ "

Optional and Accessories

WM Accessory Kit

Standards

I.A.P.M.O. Listed File 2647
ANSI-Z-124.6-97

CSA Test • Warnock Hersey Listed:
CAN/CSA-B45.0 - CAN/CSA-B45.5



FLORESTONE PRODUCTS CO., INC.

2851 Falcon Drive • Madera, CA 93637

T. 559.661.4171 • T. 800.446.8827

F. 559.661.2070 • florestone.com

**Florestone
Model WMD
Utility Sink**

45⁵/₈" x 21⁵/₈" x 13¹/₂"

WMD (1/Box):
Capacity

Weight:
62 lbs.
38 gallons

**Architect's
Specifications**

Furnish and install Utility Sink Model WMD as manufactured by Florestone Products Co. Unit to have two sinks, and come with wall mounting bracket and hardware, and drain plugs with hardware.

Color will be white and will be resistant to fading and abrasion.

Unit to have 1¹/₂" drain opening.

Optional and Accessories

WMD Accessory Kit

Standards

I.A.P.M.O. Listed File 2647
ANSI-Z-124.6-97



CSA Test • Warnock Hersey Listed:
CAN/CSA-B45.0 - CAN/CSA-B45.5

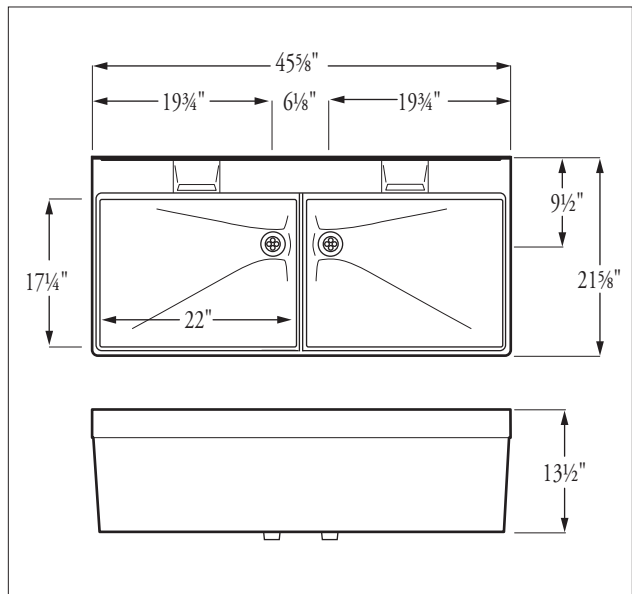

Inside Tray Dimensions: 17¹/₄" x 22"



FLORESTONE PRODUCTS CO., INC.

2851 Falcon Drive • Madera, CA 93637

T. 559.661.4171 • T. 800.446.8827

F. 559.661.2070 • florestone.com



**Florestone
Model 20FM
Utility Sink**

20" x 24" x 34⁷/₈"

20FM-1 (1/Box):
20FM-3 (3/Box):
Capacity

Weight:
30 lbs.
85 lbs.
19 gallons

**Architect's
Specifications**

Furnish and install Utility Sink Model 20FM as manufactured by Florestone Products Co. Unit to have four (4) legs and come with hardware to attach legs to sink, and drain plugs with hardware.

Color will be white and will be resistant to fading and abrasion.

Unit to have 1¹/₂" drain opening.

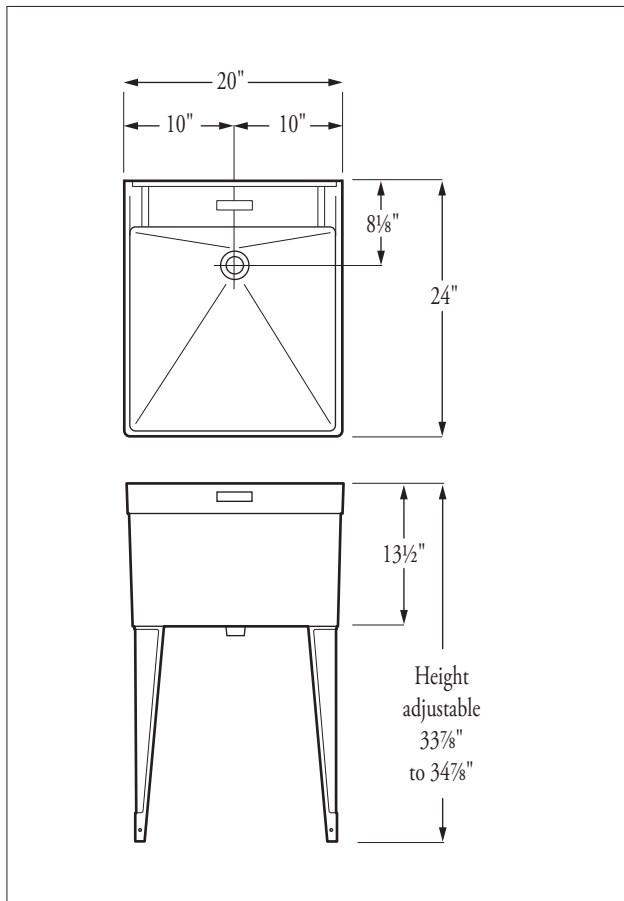

Inside Tray Dimensions: 20" x 19¹/₄"

Optional and Accessories

20FM Accessory Kit

Set of Legs (4) – Heavy duty molded legs

Standards

I.A.P.M.O. Listed File 2647
ANSI-Z-124.6-97

CSA Test • Warnock Hersey Listed:
CAN/CSA-B45.0 - CAN/CSA-B45.5



FLORESTONE PRODUCTS CO., INC.

2851 Falcon Drive • Madera, CA 93637

T. 559.661.4171 • T. 800.446.8827

F. 559.661.2070 • florestone.com

**Florestone
Model 20WM
Utility Sink**

20" x 24" x 13½"

	Weight:
20WM-1 (1/Box):	30 lbs.
20WM-3 (3/Box):	85 lbs.
Capacity	19 gallons

**Architect's
Specifications**

Furnish and install Utility Sink Model 20WM as manufactured by Florestone Products Co. Wall mounted sink to include wall mounting bracket and hardware to attach unit to wall, and drain plugs with hardware.

Color will be white and will be resistant to fading and abrasion.

Unit to have 1½" drain opening.

Optional and Accessories

20WM Accessory Kit

Standards

I.A.P.M.O. Listed File 2647
ANSI-Z-124.6-97



CSA Test • Warnock Hersey Listed:
CAN/CSA-B45.0 - CAN/CSA-B45.5

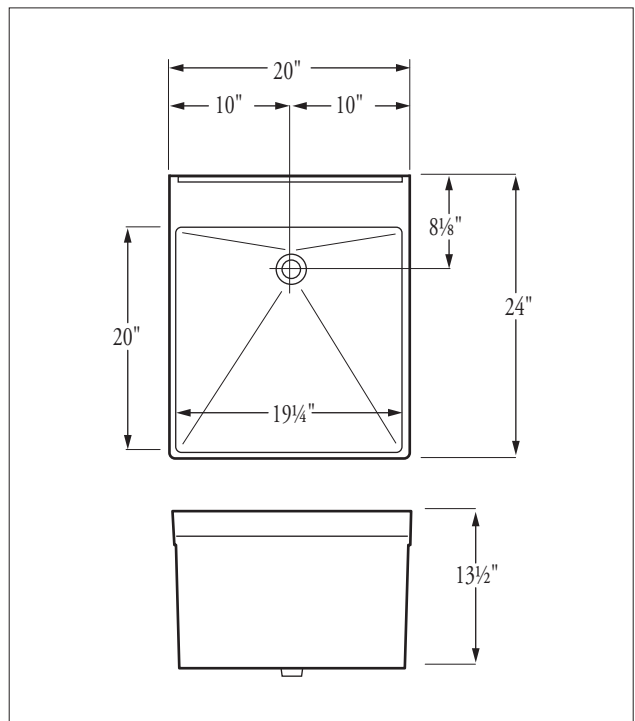

Inside Tray Dimensions: 20" x 19¼"



FLORESTONE PRODUCTS CO., INC.

2851 Falcon Drive • Madera, CA 93637

T. 559.661.4171 • T. 800.446.8827

F. 559.661.2070 • florestone.com



**Florestone
Model SC
Utility Sink**

23³/₈" x 22³/₈" x 34³/₄"

SC (1/Box):
Capacity

Weight:
65 lbs.
20 gallons

**Architect's
Specifications**

Furnish and install Utility Sink Model SC as manufactured by Florestone Products Co. Unit to consist of utility sink and metal cabinet. Doors can be hinged for right hand or left hand opening.

Color will be white and will be resistant to fading and abrasion.

Unit to have 1¹/₂" drain opening.

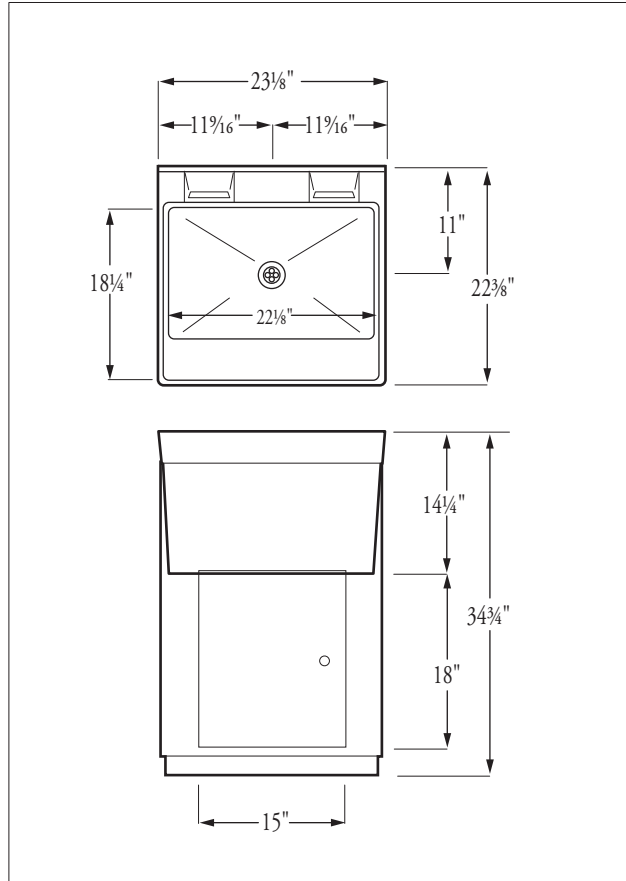

Inside Tray Dimensions: 18¹/₄" x 22³/₈"

Standards

I.A.P.M.O. Listed File 2647
ANSI-Z-124.6-97

CSA Test • Warnock Hersey Listed:
CAN/CSA-B45.0 - CAN/CSA-B45.5



FLORESTONE PRODUCTS CO., INC.

2851 Falcon Drive • Madera, CA 93637

T. 559.661.4171 • T. 800.446.8827

F. 559.661.2070 • florestone.com

**Florestone
Model SR Self-Rimming
Utility Sink**

25" x 22" x 14"

	Weight:
SR-1 (1/Box):	14 lbs.
SR-3 (3/Box):	38 lbs.
Capacity	38 gallons

**Architect's
Specifications**

Furnish and install Utility Sink Model SR as manufactured by Florestone Products Co. Unit to be self-rimming.

Color will be white and will be resistant to fading and abrasion.

Unit to have 1½" drain opening.

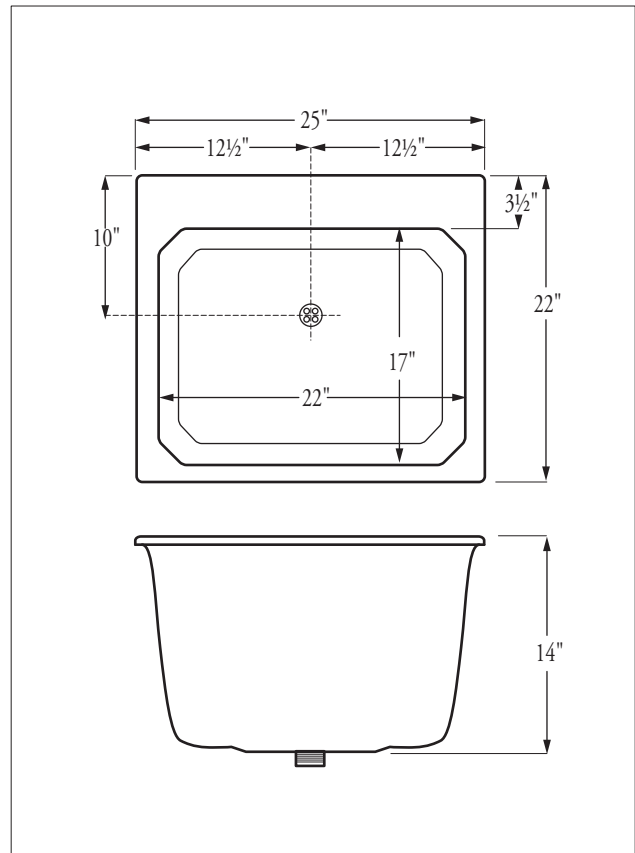

Inside Tray Dimensions: 17" x 22"

Standards

I.A.P.M.O. Listed File 2647
ANSI-Z-124.6-97



CSA Test • Warnock Hersey Listed:
CAN/CSA-B45.0 - CAN/CSA-B45.5



FLORESTONE PRODUCTS CO., INC.

2851 Falcon Drive • Madera, CA 93637

T. 559.661.4171 • T. 800.446.8827

F. 559.661.2070 • florestone.com

**Florestone
Model SR 17
Utility Sink**

17" x 20" x 10³/₄"

SR-17-1 (1/Box):
SR-17-3 (3/Box):

Weight:
8 lbs.
27 lbs.

**Architect's
Specifications**

Furnish and install Utility Sink Model SR 17 as manufactured by Florestone Products Co. Unit will be self-rimming.

Color will be white and will be resistant to fading and abrasion.

Unit to have 3¹/₂" drain opening.

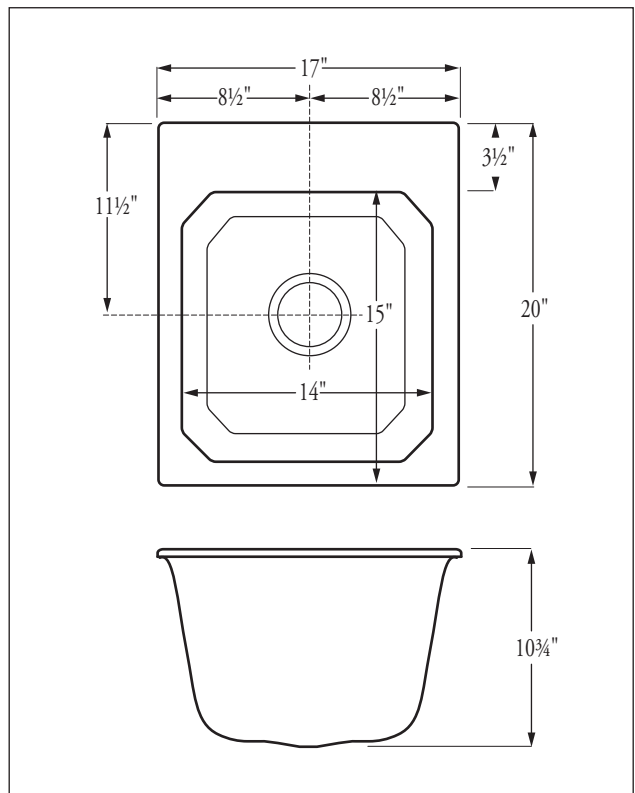

Bathing Area 52" x 32¹/₂" x 14"

Standards

I.A.P.M.O. Listed File 2647
ANSI-Z-124.6-97



CSA Test • Warnock Hersey Listed:
CAN/CSA-B45.0 - CAN/CSA-B45.5



FLORESTONE PRODUCTS CO., INC.

2851 Falcon Drive • Madera, CA 93637

T. 559.661.4171 • T. 800.446.8827

F. 559.661.2070 • florestone.com