



**Florestone
Model 20FM
Utility Sink**

20" x 24" x 34⁷/₈"

20FM-1 (1/Box):
20FM-3 (3/Box):
Capacity

Weight:
30 lbs.
85 lbs.
19 gallons

**Architect's
Specifications**

Furnish and install Utility Sink Model 20FM as manufactured by Florestone Products Co. Unit to have four (4) legs and come with hardware to attach legs to sink, and drain plugs with hardware.

Color will be white and will be resistant to fading and abrasion.

Unit to have 1¹/₂" drain opening.

Optional and Accessories

20FM Accessory Kit
Set of Legs (4) – Heavy duty molded legs

Standards

I.A.P.M.O. Listed File 2647
ANSI-Z-124.6-97

CSA Test • Warnock Hersey Listed:
CAN/CSA-B45.0 - CAN/CSA-B45.5

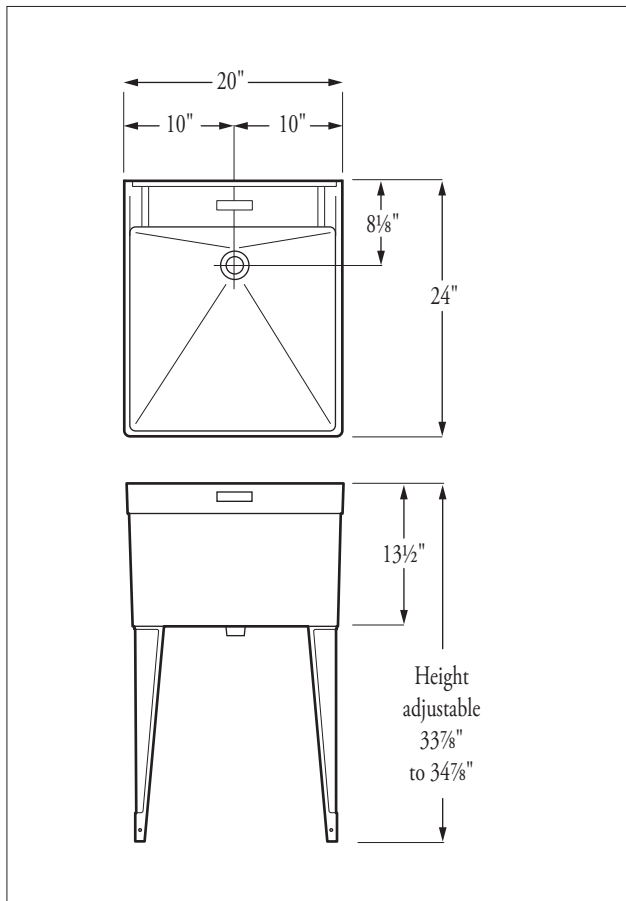

Inside Tray Dimensions: 20" x 19¹/₄"



FLORESTONE PRODUCTS CO., INC.

2851 Falcon Drive • Madera, CA 93637
T. 559.661.4171 • T. 800.446.8827
F. 559.661.2070 • florestone.com